

SmartFan® Multi SD

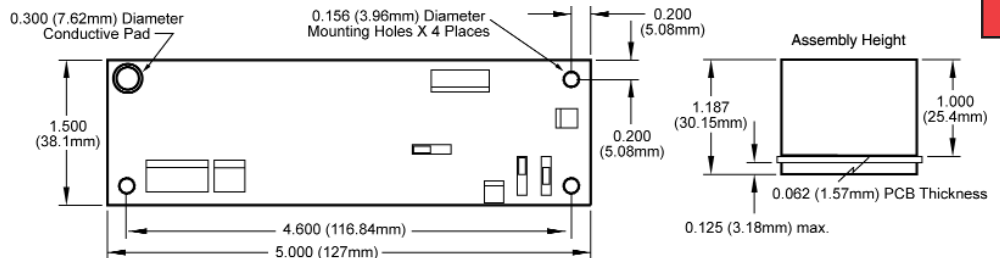

Speed Control for DC Fans

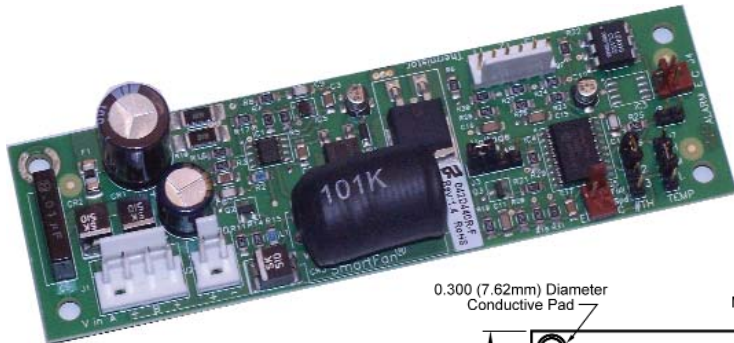

DC Controls

SmartFan Multi SD is a fan speed control and temperature alarm designed for DC fans and blowers. Multi SD accepts and diode ORs dual power feeds in the range from 10 to 75 VDC. It can control 12, 24 or 48 VDC fans and operates at a high frequency to achieve maximum power efficiency at minimum size. Fan speed control is based on temperature from up to three temperature sensors. Voltage to the fans is varied using a current mode buck control circuit. Multi SD is supplied with an optically isolated temperature alarm, triggered if sensor temperature reaches 10°C above control temperature or if cooling system power is lost.

FEATURES

- Accepts and diode ORs dual power feeds
- Soft start and current limiting at start up
- Accepts temperature (thermistor) inputs from up to three OR'd sensors and provides proportional speed control to the fans
- Compatible with SmartFan TachScan-3 and TachScan-9 speed alarms
- Small size of 1.5" X 5.0" permits mounting in small spaces within fan trays, etc.
- High power efficiency: typically greater than 90%
- Noise reduction: typically 15 dB(A) or more at idle speed
- Jumpers allow user selectable settings of:
 - 12, 24 or 48 VDC operation (maximum output voltage is limited to input voltage)
 - 35, 40 or 45°C Control Temperature
 - 1, 2 or 3 temperature sensors
- Temperature alarm output through optical isolator or MOS relay
- RoHS (6/6) compliant
- UL Recognized to UL508 and CSA-C22.2, File E100344 
- EN 60950 : 2000 Compliant 

SPECIFICATIONS

Part Number	Supply Voltage Range	Maximum Watts to Fans ²		Isolated Temperature Alarm Sinking Current
		200 Ft/Min	Still Air	
042D440-F ¹	10 to 75 VDC	5.0 Amps	4.0 Amps	1 mA
042D440R-F ¹				100 mA
H118-F	Hardware Pack			

¹Temperature sensor required. See sensors page.

²Air temperature of 55 °C or less

For complete product details visit: www.controlres.com

FEATURES:

Input Power: The Multi-SD can accept one or two power sources in the range of 10-75 VDC. If two power supplies are used, they are logically OR'd on the Multi-SD so that the operating voltage is equal to the higher of the two supplies. The Multi-SD can supply up to 4.0 Amps to the fan load with natural convection or 5.0 Amps to the fan load with 200 LFPM of forced convection, at 12, 24 VDC or 48 VDC.

Input Power Fuse: A 7.0 Amp input power fuse is provided to protect the Multi-SD from over-current conditions.

Inrush Current: The input power supply connected to the Multi-SD will see 100 microfarads of capacitance through 0 Ohms.

Fan Soft Start: At the application of power, the Multi-SD output voltage starts at 0 VDC. Then, over a period of approximately 5 seconds the fan voltage is modulated from 0 VDC to full voltage and then temperature (or PWM) based control begins.

Fan Speed Control: The speed of all fans is varied by adjusting the voltage applied to the fan(s). Voltage adjustment is accomplished with a current mode, buck type control circuit. The fan voltage range is 6.6-13 VDC for 12 VDC fans, 13-25 for 24 VDC fans and 26-50 VDC for 48 VDC fans.

Fan Current Limiting: The load regulating circuitry is configured with a 5 Amp active current limit.

Multiple Control Temperature Settings: Three control temperatures (35°, 40°C or 45°C) are selectable by jumper.

Temperature based fan control: The voltage applied to the fan(s) is determined by the temperature sensor(s) connected to header J8. Single point or multiple point sensing can be accomplished by connecting one to three thermistor sensors to positions T1, T2 and T3. The sensor reading the hottest temperature is used for fan voltage control when more than one sensor is used.

PWM based fan control: The voltage applied to the fans can be controlled based on an isolated PWM signal applied to position T3 on header J8.

Fan Speed Up Command Input: A non-isolated input at header J5 allows the user to apply a signal that commands the fans to go to full speed. This command over-rides the temperature sensor or PWM input signals at header J8.

Temperature Alarm: An isolated alarm output provides indication of a high temperature condition or a shorted or open sensor. Temperature alarm output is from an open collector output or MOS relay.

Specialized Configurations of the Multi-SD

The following parameters can be specialized by CRI through software and/or component values changes:

- Relationship between sensed temperatures and fan voltage
- Relationship between PWM control signal and fan voltage
- Temperature alarm trigger point
- Fan turn off below a certain sensed temperature

Customized Configuration of the Multi-SD

Contact Control Resources' Sales Department for details on custom products.

Agency Approvals



UL Recognized to UL508 and CSA-C22.2 File E100344



EN 60950:2000 Compliant

INSTALLATION

Mounting

Using the PCB support hardware in hardware pack H118-F, or equivalent, mount the Multi-SD on a flat surface using all four mounting holes for maximum support. To minimize EMI, securely mount the unit on a grounded surface using a metal spacer and hardware at the mounting hole that is surrounded by a conductive pad.

CONNECTIONS

Connector Pin Assignments:

A description of the function of each connector pin and location is listed in Table 1. Depending on the model number and configuration of the Multi-SD, some headers may not need to be connected.

Header Label	Description
J1	A Power Supply A
	+ Power Supply A Reference
	B Power Supply B
	+ Power Supply B Reference
J2	+ Fan Power
	- Fan Power Reference
J4	C Temperature Alarm Output, Collector Terminal (+)
	E Temperature Alarm Output, Emitter Terminal (-)
J5	C High Speed Command Input (+)
	E High Speed Command Input Reference (-)
J8	T1 Temperature Sensor 1 Input
	T1 Temperature Sensor 1 Input
	T2 Temperature Sensor 2 Input
	T2 Temperature Sensor 2 Input
	T3 Temperature Sensor 3 Input (Or PWM Signal Input)
	T3 Temperature Sensor 3 Input (Or PWM Signal Reference)

Suggested Connecting Hardware

Use CRI Hardware Pack H118-F containing the following components shown in Table 2.

Ref. Des.	Header Mfg. & Part No. ¹	H118-F Hardware Pack		
		Qty	Description	Mfg. & Part No. ¹
J1	Molex No. 26-60-4040	1	Housing	Molex No. 09-50-8041
		4	Terminal (Tin)	Molex No. 08-50-0106
J2	Molex No. 26-60-4020	1	Housing	Molex No. 09-50-8021
		2	Terminal (Tin)	Molex No. 08-50-0106
J4	Molex No. 22-29-2021	1	Housing	Molex No. 22-01-2027
		2	Terminal (gold)	Molex No. 08-55-0102
J5	Molex No. 22-29-2021	1	Housing	Molex No. 22-01-2027
		2	Terminal (gold)	Molex No. 08-55-0102
J8	Molex No. 22-29-2061	1	Housing	Molex No. 22-01-3067
		6	Terminal (gold)	Molex No. 08-55-0102
Mounting Hardware		4	PCB Support	Richco No. CBS-4-19
		1	Aluminum Spacer	Richco No. ALSS6-2
		1	Screw, 6-32x5/8"	
		1	Nut, 6-32	

¹ Or equivalent

Input Power Connection to header J1

Refer to Figure 1 for input power wiring. One or two power supplies in the range of 10 to 75 VDC should be connected at header J1. If two power supplies are used, they are logically OR'd on the Multi-SD so that the operating voltage is equal to the higher of the two supplies. An OR'ing diode is located in the A & B power supply reference legs. The Multi-SD can supply up to 4.0 Amps (still air) and 5.0 Amps (200 LFPM air stream) at 12, 24 VDC or 48 VDC to the fan load.

-48 VDC Telecomm Power System Note: When a -48 VDC power system is used to supply power to the Multi-SD, connect -48 VDC Power Return to J1:+ and -48 VDC Power to J1:A or J1:B.

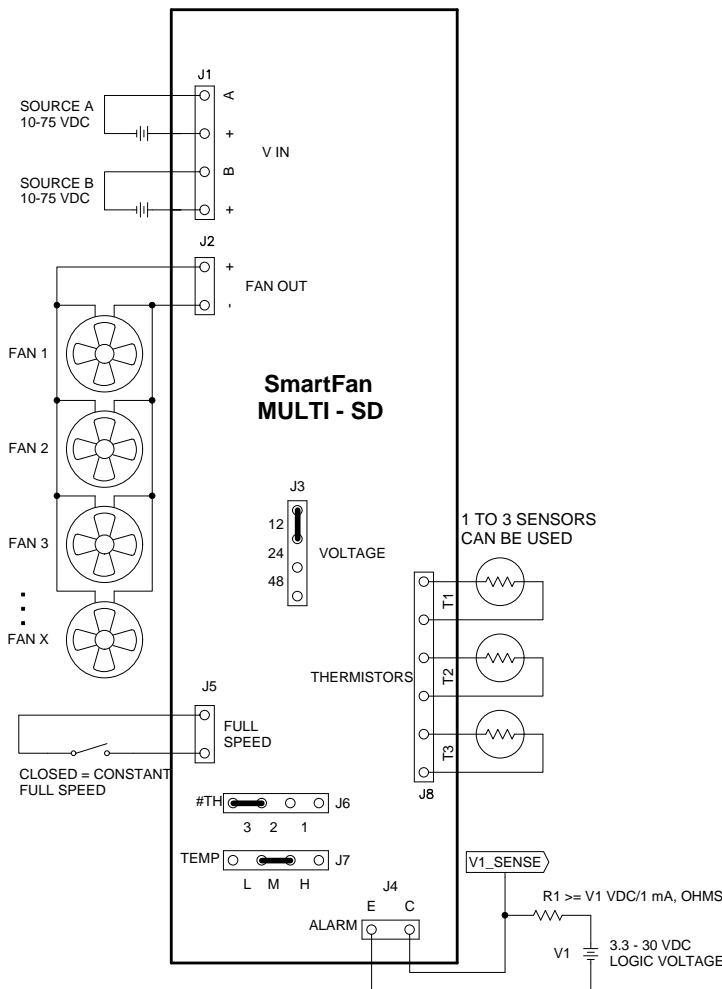

Figure 1: Multi-SD wiring diagram for temperature sensor based control.

Fan Connection to header J2

Fans are connected to header J2. Refer to Figure 1 for details of fan power wiring. More than one fan can be connected in parallel to header J2 as long as the total current draw of the fan load does not exceed the rating of the Multi-SD.

Connection of Remote Thermistor(s) to header J8

One to three thermistor sensors can be connected to the Multi SD to provide temperature based fan speed control and alarming. Referring to Figure 1, connect the thermistor(s) to header J8. There is no polarity consideration when connecting the sensor(s). The thermistor reading the highest temperature is used for speed control and alarming. If no sensors are connected to header J8, fans continually operate at full voltage and the temperature alarm output at header J4 is open.

Connection of PWM Control Signal to header J8:T3

The Multi SD can control fan speed based on an isolated PWM control signal. Referring to Figure 2, connect the voltage signal to header J8:T3. Header J8:T3 is internally pulled up to 4 VDC with a 10.0k Ohm resistor. Isolation of PWM signal is required because the circuitry at J8:T3 is referenced to a floating voltage on the Multi-SD. When a PWM signal is applied to J8:T3, no connections should be made to T1 or T2.

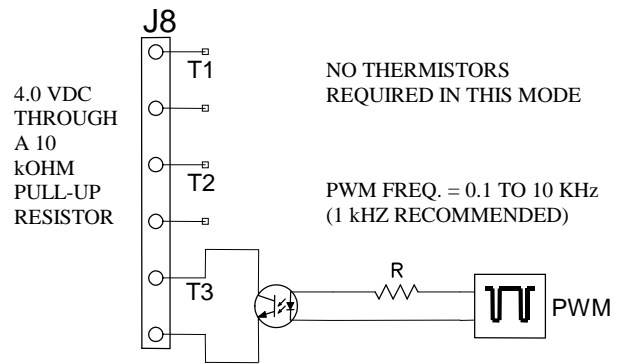

Figure 2: Connection diagram for PWM control signal input.

Connection of an alarm circuit to header J4

An optically isolated open collector circuit output is connected to header J4 to provide remote indication of a high temperature condition. Referring to Figure 1, connect logic circuitry to header J4. The alarm outputs must be current limited as shown in Figure 1.

Multi-SDs featuring the MOS relay alarm output should be connected as indicated in Figure 1 except that the current limiting resistor value is calculated using $R1 = V1/100mA$ (Ohms), where V1 can be up to 230 VAC.

Connection of a fan speed up input signal to header J5

A non-isolated input is located at J5 that allows the user to command the fans to full speed when a short circuit is placed across the two header pins. Refer to Figure 1 for wiring details.

Speed Up Command from a Tachscan-3: An example of how this input can be interfaced with the Tachscan-3 is shown in Figure 3. In this case, the normally open isolated alarm output (J8:2A, 2B) from the Tachscan-3 is connected to header J5 on the Multi-SD. When the Tachscan-3 senses that the speed of one or more fans drops below the trigger speed, the output closes and the Multi-SD increases the speed of the fans to full. See the Tachscan-3 product pages for additional details. Similar configurations can be used with the Tachscan-9.

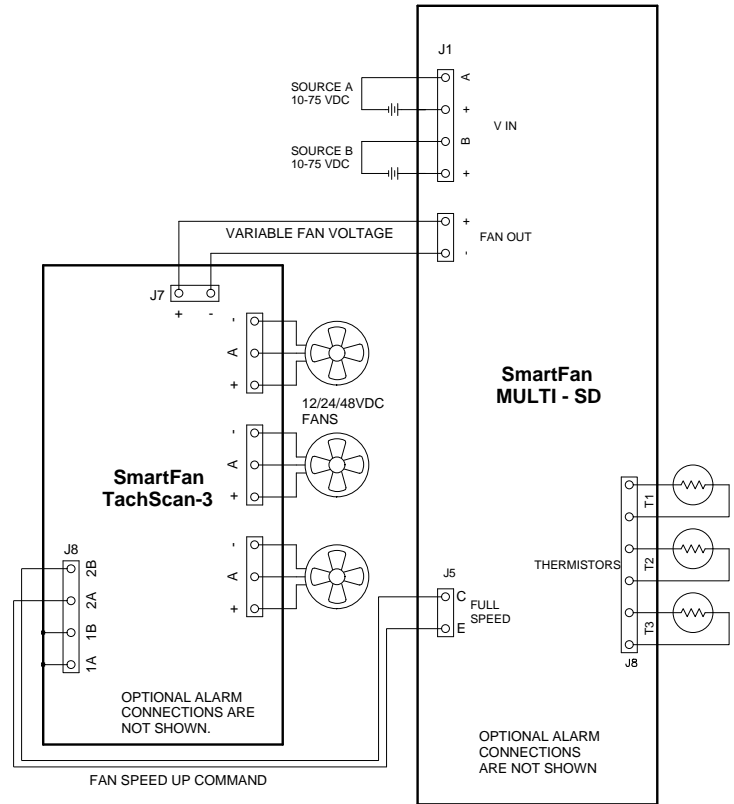

Figure 3: Connection diagram for interface of Tachscan-3 and Multi-SD. Only connections to implement the speed-up function are shown.

OPERATION

Remote Sensor Selection (J8)

The Multi-SD is compatible with Sensors P1-F through P9-F shown on SmartFan Catalog Sensor page. Control temperature is a function of the temperature sensor selected and the position of the shunt (S3) on header J7.

Jumper Settings (J3, J6, J7)

There are three jumper settings that must be reviewed prior to applying power to the Multi-SD: Output Voltage (J3), Control Temperature (J7) and Number of Thermistors (J6). Settings are based on the particular application. Following is a description of each jumper setting.

Output Voltage Setting (J3): The Multi-SD can provide power to 12 VDC, 24 VDC or 48 VDC fans from a 10-75 VDC input voltage source. Table 3 describes the function of each setting. If the shunt is removed, the default fan type is 12 VDC.

Position on Header J3	Fan Voltage
12V (Factory Setting)	6.6 – 13 VDC
24V	13 – 25 VDC
48V	25 – 50 VDC

Number of Thermistor Sensors (J6): Use shunt S2 on header J6 to indicate the number of thermistor sensors that are connected to header J8. Table 4 describes the function of each setting. When controlling based off of a PWM input control signal shunt S2 should be in the 1 position on header J6.

Position on Header J6	Number of Sensor Inputs
1 (Factory Setting)	1 (PWM Control)
2	2
3	3

Control Temperature Setting (J7):

The control temperature is the temperature at which the maximum voltage is applied to the fans. Header J7 allows selection from three different control temperatures. Table 5 shows the control temperature value for each jumper setting. If the jumper is removed, the default setting is M.

Position on Header J7	Control Temperature
L	35°C
M (Factory Setting)	40°C
H	45°C

Fan Speed Control

Temperature based fan control: The voltage applied to the fan(s) is determined by the temperature sensor(s) connected to header J8. Single point or multiple point sensing can be accomplished by connecting one to three thermistor sensors to positions T1, T2 and T3. The sensor reading the hottest temperature is used for fan voltage control when more than one sensor is used. The relationship between fan voltage and sensed temperature is shown in Figure 4.

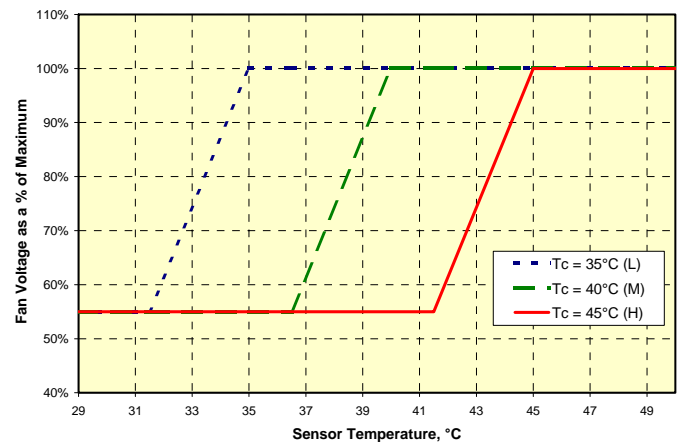

Figure 4: Fan voltage vs. sensor temperature for each control temperature setting.

PWM based fan control: The voltage applied to the fans can be controlled based on an isolated PWM signal applied to position T3 on header J8. PWM switching frequency should be in the range of 0.1 to 10 kHz. Figure 5 shows the relationship between the control signal applied at header J8:T3 and the fan voltage. NOTE: Fan voltage is 100% at a duty cycle of 0%. When a PWM signal is applied to J8:T3, no connections should be made to T1 or T2. When controlling based off of a PWM input control signal shunt S2 should be in the 1 position on header J6.

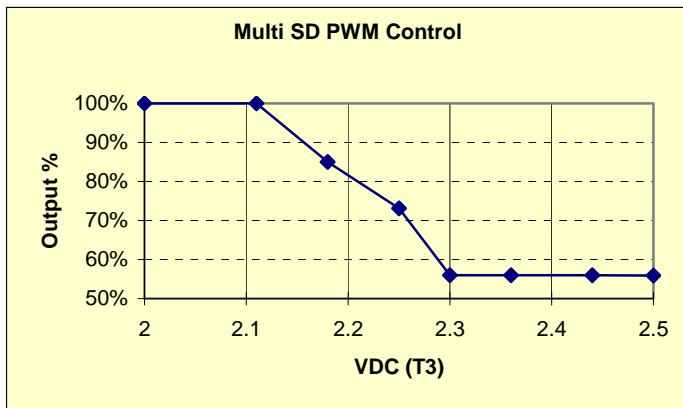

Figure 5: Fan voltage vs. control signal input.

Note: Alternative control curves can be provided on special request. Contact Control Resources' Sales Department for details

High Temperature Alarm (J4)

A normally closed alarm output is provided at header J4 to indicate when the sensed temperature is 10°C above the control temperature. Table 6 shows the status of the alarm output under various operating conditions and Table 7 shows the electrical rating of each output type.

Operating Condition	Alarm Status Across J4:C-E
Sensed temperature < 10°C above control temperature	Closed (LOW resistance)
Sensed temperature > 10°C above control temperature	Open (HIGH resistance)
Power Removed from Multi-SD	Open (HIGH resistance)
Open or Missing Thermistor	Open (HIGH resistance)
Shorted Thermistor	Open (HIGH resistance)

Output Type	Max. Sink Current	Max. Applied Voltage
Open Collector P/N 042D440	1 mA at <= 0.4 VDC	30 VDC
MOS Relay P/N 042D440R	100 mA at <= 0.5 VDC	230 VAC